



PR-L

Aspiratori centrifughi pale rovesce per aria pulita o leggermente polverosa

Backward curved blade centrifugal fans for clean or slightly dusty air



ErP 125/2009/CE



UE 327/2011

Conformi

Direttiva ErP 125/2009/CE e al Regolamento UE 327/2011

Comply

ErP Directive 125/2009/CE and EU Regulation 327/2011

Classifica | Classification:
FAN

VERSIONI | VERSIONS



PR-L ATEX

Versione antideflagrante secondo la Direttiva 2014/34/UE
Explosion-proof version according to Directive 2014/34/UE



PR-L INOX

Versione resistente all'azione corrosiva, realizzata con cassa, boccaglio e girante in acciaio inossidabile AISI304/316 L
Corrosion-resistant version with casing, nozzle and impeller in AISI304/316L stainless steel



PR-L AT

Versione idonea al trasporto di gas caldi, max 150°C [PR-L/AT es 4] e max 300°C [PR-L/AT es 1-12]
Version suitable for transporting hot gases, max. 150°C [PR-L/AT arrangement 4] and max. 300°C [PR-L/AT arrangement 1-12]

DESCRIZIONE

I ventilatori della serie **PR-L** trovano la loro principale applicazione nell'impiantistica industriale e nel condizionamento.

GAMMA

Diametri da 250 a 1.400 mm
Portate da 2.500 a 140.000 m³/h
La serie prevede esecuzioni direttamente accoppiate (esecuzione 4) e a trasmissione (esecuzione 1, 9 e 12).

TEMPERATURA DI ESERCIZIO

Temperature da -10°C a +60°C nella configurazione standard, e fino a 300°C con costruzioni speciali.

COSTRUZIONE

- Cassa a spirale realizzata in lamiera d'acciaio e protetta contro gli agenti atmosferici con vernici a polveri epossipoliestiriche.
- Boccaglio d'aspirazione con ampio raggio realizzato in lamiera d'acciaio e protetto contro gli agenti atmosferici con vernici a polveri epossipoliestiriche.
- Girante a semplice aspirazione con pale rovesce curve ad alto rendimento aerale, realizzata in lamiera e verniciata con vernici a polveri epossipoliestiriche. Sono previste versioni per alte velocità di rotazione in classe 3.
- Per esecuzione 1 - 9 - 12: supporto monoblocco realizzato in fusione di ghisa, con cuscinetti a sfera, progettati per agevolare le operazioni di lubrificazione. Cinghie di trasmissione, pulegge e supporto motore. Carter di protezione per le cinghie.

MOTORE

Motore asincrono trifase a norme internazionali IEC 60034, IEC 60072, EMC 2014/30/UE, LVD 2014/35/UE e marcato CE IP55, classe F, idonei ad un servizio S1 (funzionamento continuo a carico costante).

ACCESSORI

- Controflangia per bocca aspirante
- Controflangia per bocca premente
- Rete di protezione per bocca aspirante
- Rete di protezione per bocca premente
- Giunto antivibrante per bocca aspirante
- Giunto antivibrante per bocca premente

DESCRIPTION

The **PR-L** series of fans are mainly used in industrial and air conditioning applications.

RANGE

Diameters from 250 to 1,400 mm
Airflow from 2,500 to 140,000 m³/h
The series includes directly coupled (version 4) and transmission versions (versions 1, 9 and 12).

OPERATING TEMPERATURE

Temperatures from -10°C to +60°C in the standard configuration, and up to 300°C with special constructions.

CONSTRUCTION

- Volute casing made of steel sheet and protected against atmospheric agents with epoxy paint.
- Wide radius suction nozzle made of sheet steel and protected against atmospheric agents with epoxy paint.
- Single inlet impeller with backward curved blades with high aerale efficiency, made of steel sheet and coated with epoxy paint. Versions for high-speed rotation in class 3 are available.
- For execution 1 - 9 - 12: mono-block support in cast iron with ball bearings, designed for easy lubrication. Pulleys, belts and motor support. Belt protection guard.

MOTOR

Asynchronous three-phase motors according to international standards IEC 60034, IEC 60072, EMC 2014/30/UE, LVD 2014/35/UE, CE marked, IP 55, class F, suitable to S1 service (continuous working at constant load).

ACCESSORIES

- Inlet counter-flange
- Outlet counter-flange
- Inlet protection guard
- Outlet protection guard
- Inlet flexible connector
- Outlet flexible connector

CAMPO D'IMPIEGO | OPERATION FIELD

PR-L

Questo grafico ha il solo scopo di rappresentare le aree di funzionamento dei modelli disponibili. Per una selezione precisa utilizzare i grafici prestazionali presenti di seguito oppure contattate il nostro servizio tecnico commerciale.

This graph is only meant to represent the operating areas of the available models. For an accurate selection please use the performance graphs below or contact our technical sales department.

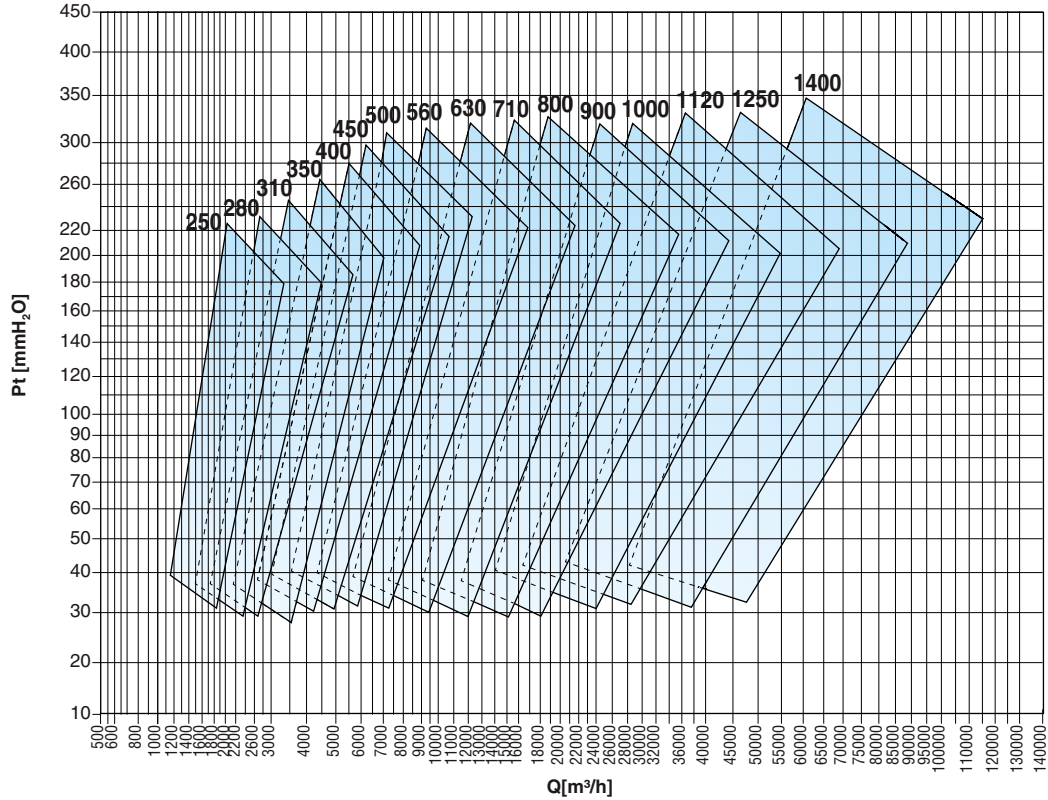

Grandezza ventilatore Fan size	RPM MAX		
	Classe I	Classe II	Classe III
PR-L 250	4000	5000	6000
PR-L 280	3800	4500	5300
PR-L 310	3600	4100	4750
PR-L 350	3250	3700	4250
PR-L 400 R	2950	3300	3900
PR-L 400	2950	3300	3900
PR-L 450 R	2750	3150	3800
PR-L 450	2550	2955	3550
PR-L 500 R	2350	2750	3350
PR-L 500	2250	2600	3150
PR-L 560 R	2100	2450	3000
PR-L 560	2000	2300	2850
PR-L 630 R	1850	2150	2650
PR-L 630	1750	2050	2500
PR-L 710 R	1900	2300	2550
PR-L 710	1800	2200	2400
PR-L 800 R	1700	2050	2300
PR-L 800	1600	1950	2150
PR-L 900 R	1500	1850	2000
PR-L 900	1450	1750	1900
PR-L 1000 R	1350	1650	1800
PR-L 1000	1250	1550	1700
PR-L 1120 R	1250	1350	1450
PR-L 1120	1200	1300	1400
PR-L 1250 R	1150	1250	1350
PR-L 1250	1100	1200	1300
PR-L 1400 R	1050	1150	1250
PR-L 1400	1000	1100	1200

VALORI RPM VALIDI FINO A 60°C RPM VALUES VALID UP TO 60°C

Fra Between	E And	Declassare velocità Degrade speed
60°C	100°C	4%
100°C	150°C	10%
150°C	200°C	16%
200°C	250°C	23%
250°C	300°C	30%
300°C	350°C	37%
350°C	400°C	45%
400°C	450°C	54%
450°C	500°C	64%

.sez
1.5

PRESTAZIONI | PERFORMANCE

PR-L

Le curve prestazionali rappresentate nel presente catalogo sono state ricavate eseguendo prove sui ventilatori in accordo alla normativa ISO 5801 "Metodi di prova e condizioni di accettazione" (che sostituisce la ISO 1053:1995 ed è in accordo con la UNI EN ISO 5801:2009). Per eseguire le prove i ventilatori sono stati installati secondo quanto previsto per la categoria B: con bocca d'aspirazione libera e bocca premonte collegata al banco prova. L'efficienza dei ventilatori è conforme all'obiettivo del regolamento (UE) N.327/2011, come richiesto dalla Direttiva 2009/125/CE.

The performance curves given in this catalogue were calculated by performing tests on fans in compliance with ISO 5801 "Test methods and terms of acceptance" [which replaces UNI 10531:1995 and complies with UNI EN ISO 5801:2009]. To carry out the tests the fans were installed in compliance with the requirements for category B: with free inlet and outlet connected to the test station. The fan efficiency conforms to the objective of Regulation (EU) N.327/2011, as required by Directive 2009/125/EC.

Lw La determinazione del livello di potenza sonora è stata condotta secondo la norma UNI EN ISO 3746: 1997 (Metodo di controllo con una superficie avvolgente su un piano riflettente). Alle misure sono state applicate correzioni in funzione del rumore di fondo e del riverbero ambientale. Measurement of the sound power level was carried out in compliance with UNI EN ISO 3746: 1997 (Survey method using an enveloping measurement surface over a reflecting plane). The measurements were subjected to corrections to take account of background noise and ambient reverberation levels.

PR-L 250-280

Code	Tipo Type	Modello Model	U	P	Pm (kW)	In (A)	IE3	IP/CL
7PR2809	PR-L	252	T	2	0,55	1,27	-	55/F
7PR2803		282	T	2	1,10	2,50	✓	55/F

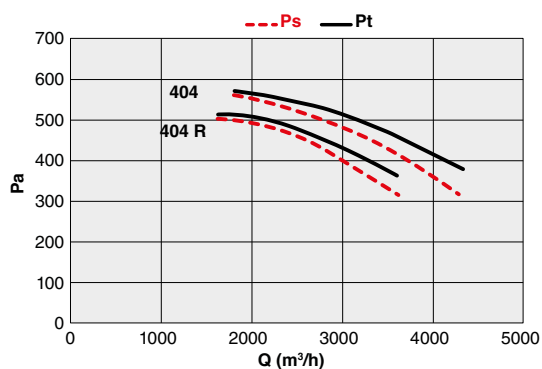
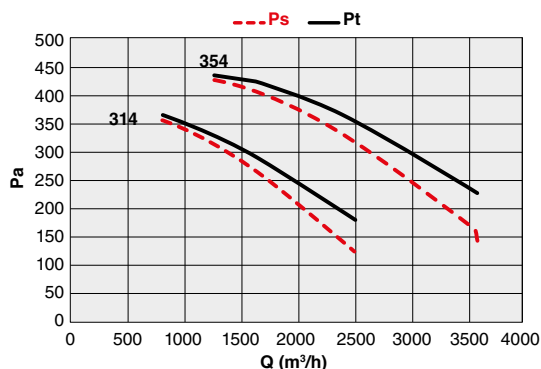
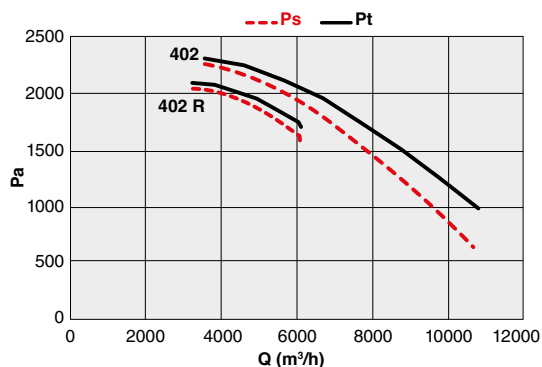
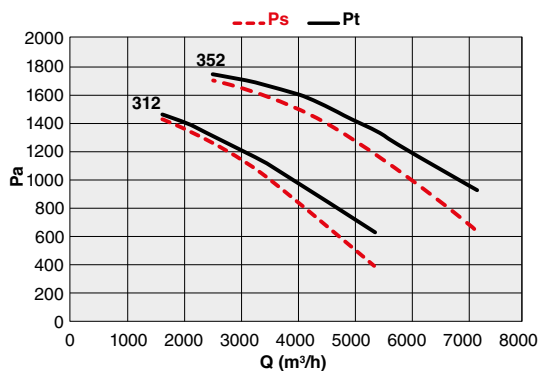
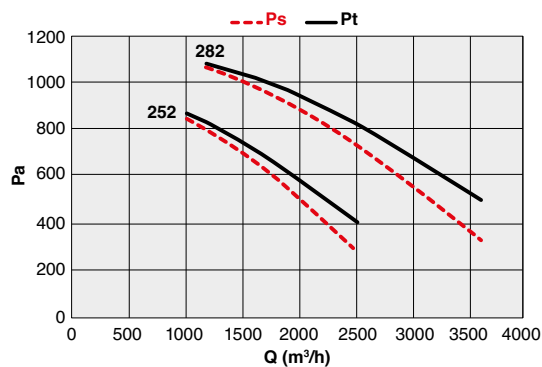

PR-L 310-350

Code	Tipo Type	Modello Model	U	P	Pm (kW)	In (A)	IE3	IP/CL
7PR3108	PR-L	312	T	2	2,20	4,90	✓	55/F
7PR3112		314	T	4	0,18	0,60	-	55/F
7PR3501		352	T	2	3,00	6,40	✓	55/F
7PR3502		354	T	4	0,37	1,18	-	55/F

PR-L 400

Code	Tipo Type	Modello Model	U	P	Pm (kW)	In (A)	IE3	IP/CL
7PR4108	PR-L	402 R	T	2	4,00	8,00	✓	55/F
7PR4010		402	T	2	5,50	10,80	✓	55/F
7PR4005		404 R	T	4	0,55	1,60	-	55/F
7PR4109		404	T	4	0,75	2,00	✓	55/F

.SEZ
1.5

PR-L aspiratori | centrifugal fans

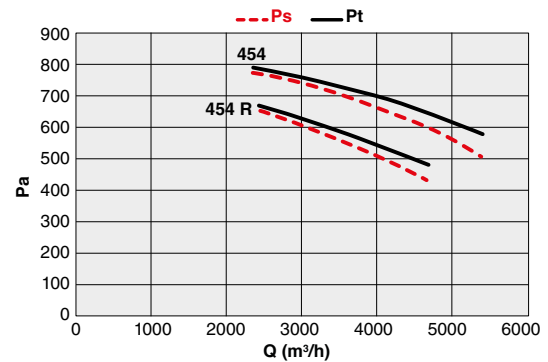
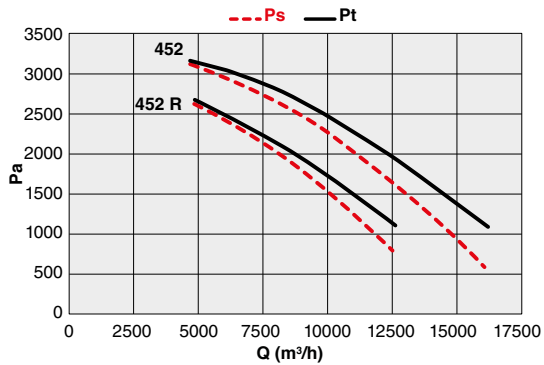

PR-L 450

Code	Tipo Type	Modello Model	U	P	Pm (kW)	In (A)	IE3	IP/CL
7PR4607	PR-L	452 R	T	2	7,50	14,10	✓	55/F
7PR4505		452	T	2	11,00	20,40	✓	55/F
7PR4608		454 R	T	4	0,75	2,00	✓	55/F
7PR4507		454	T	4	1,10	2,70	✓	55/F

PR-L 500

Code	Tipo Type	Modello Model	U	P	Pm (kW)	In (A)	IE3	IP/CL
7PR5130	PR-L	502 R	T	2	15,00	27,50	✓	55/F
7PR5006		502	T	2	18,50	33,00	✓	55/F
7PR5131		504 R	T	4	1,50	3,60	✓	55/F
7PR5005		504	T	4	2,20	5,40	✓	55/F
7PR5132		506 R	T	6	0,37	1,20	-	55/F
7PR5016		506	T	6	0,55	1,80	-	55/F

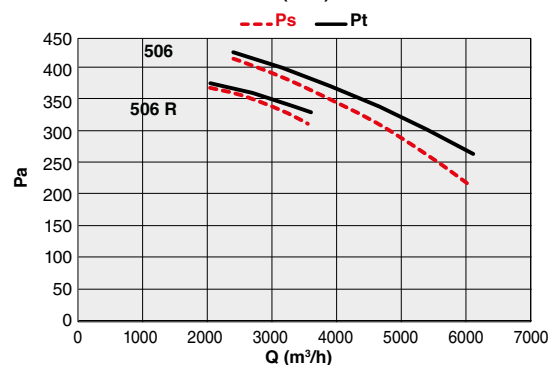
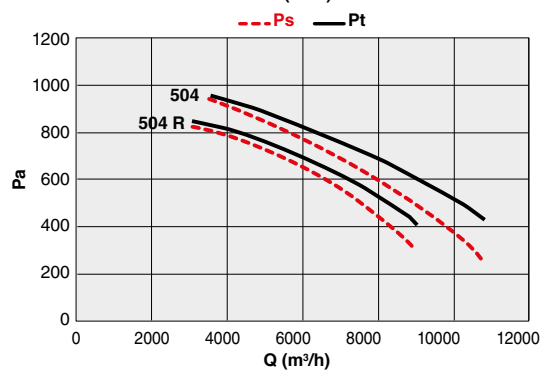
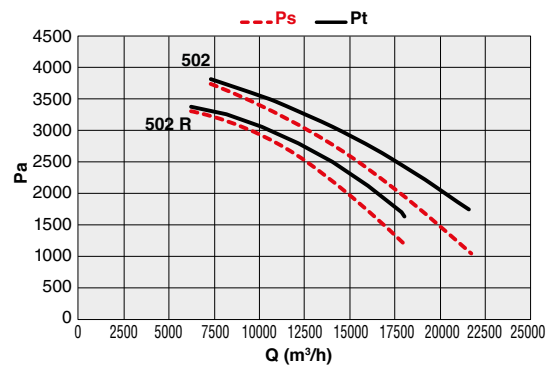

PR-L 560

Code	Tipo Type	Modello Model	U	P	Pm (kW)	In (A)	IE3	IP/CL
7PR5710	PR-L	564 R	T	4	3,00	6,80	✓	55/F
7PR5607		564	T	4	4,00	8,50	✓	55/F
7PR5711		566 R	T	6	0,75	2,10	✓	55/F
7PR5604		566	T	6	1,10	3,50	✓	55/F

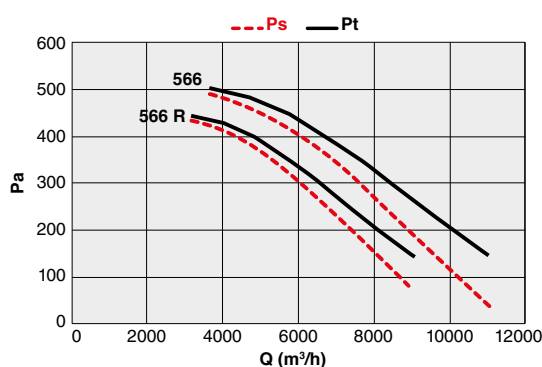
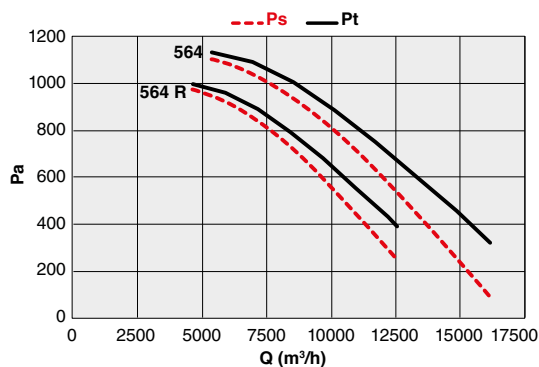

PR-L 630

Code	Tipo Type	Modello Model	U	P	Pm (kW)	In (A)	IE3	IP/CL
7PR6404	PR-L	634 R	T	4	5,50	11,30	✓	55/F
7PR6342		634	T	4	7,50	14,70	✓	55/F
7PR6405		636 R	T	6	1,50	3,90	✓	55/F
7PR6371		636	T	6	2,20	5,30	✓	55/F

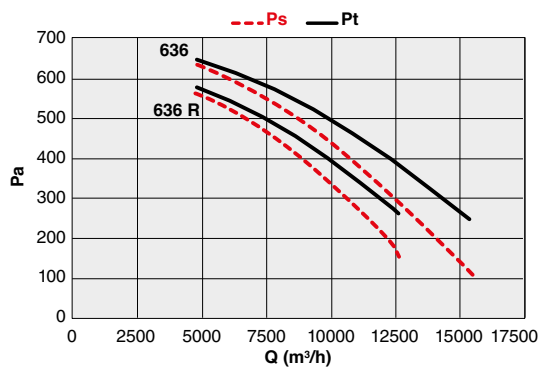
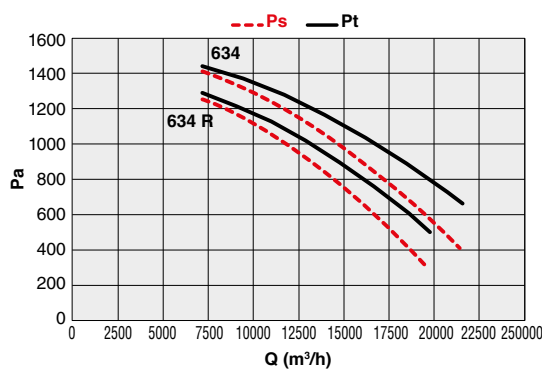

PR-L 710

Code	Tipo Type	Modello Model	U	P	Pm (kW)	In (A)	IE3	IP/CL
7PR7099	PR-L	714 R	T	4	11,00	22,00	✓	55/F
7PR7000		714	T	4	15,00	29,00	✓	55/F
7PR7100		716 R	T	6	3,00	6,60	✓	55/F
7PR7002		716	T	6	4,00	9,10	✓	55/F

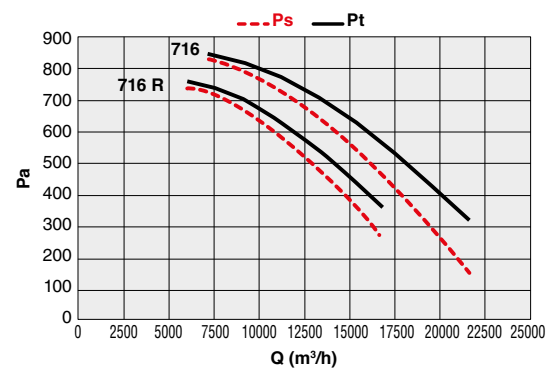
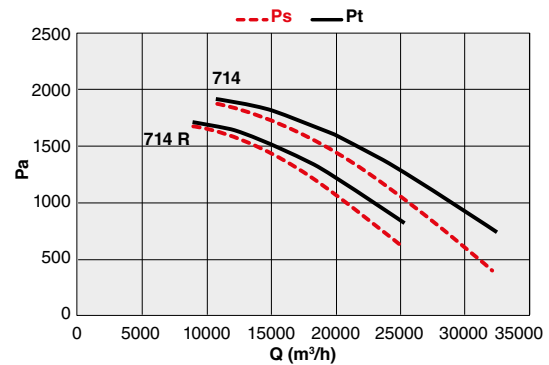

PR-L 800

Code	Tipo Type	Modello Model	U	P	Pm (kW)	In (A)	IE3	IP/CL
7PR8000	PR-L	804 R	T	4	18,50	35,00	✓	55/F
7PR8013		804 A	T	4	22,00	41,00	✓	55/F
7PR8062		806 R	T	6	5,50	12,30	✓	55/F
7PR8012		806	T	6	7,50	15,20	✓	55/F

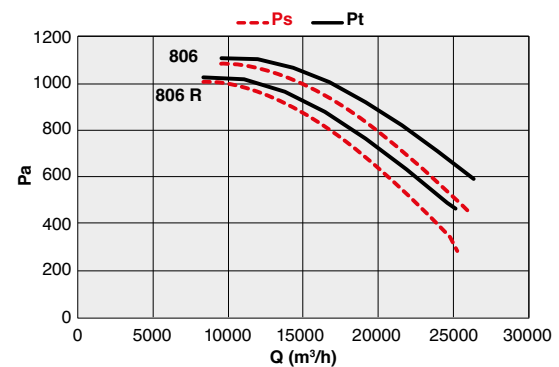
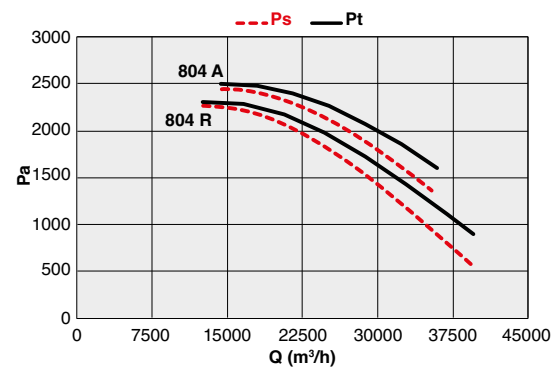

PR-L 900

Code	Tipo Type	Modello Model	U	P	Pm (kW)	In (A)	IE3	IP/CL
7PR9044	PR-L	904 R	T	4	37,00	68,00	✓	55/F
7PR9003		904	T	4	45,00	80,50	✓	55/F
7PR9045		906 R	T	6	11,00	20,40	✓	55/F
7PR9021		906	T	6	15,00	29,00	✓	55/F

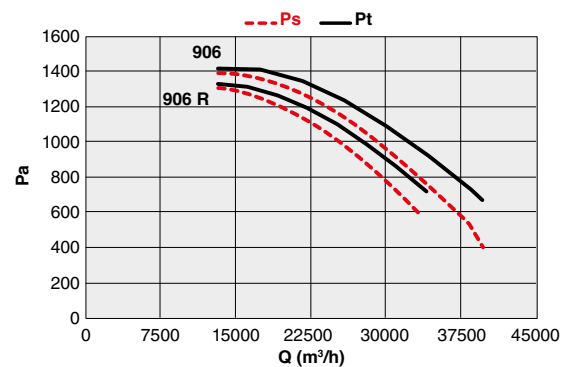
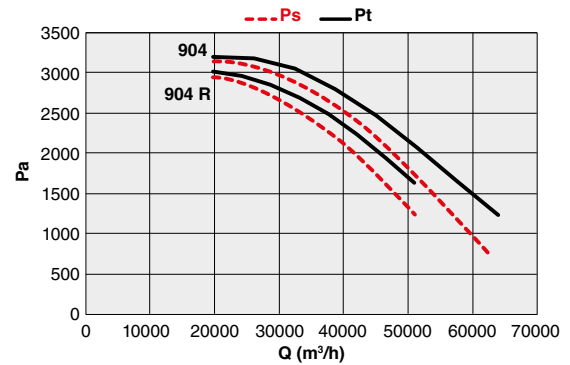

PR-L 1000

Code	Tipo Type	Modello Model	U	P	Pm (kW)	In (A)	IE3	IP/CL
7PR1129	PR-L	1004 R	T	4	55,00	97,61	✓	55/F
7PR1005		1004	T	4	75,00	134,00	✓	55/F
7PR1130		1006 R	T	6	18,50	37,50	✓	55/F
7PR1023		1006	T	6	22,00	42,50	✓	55/F

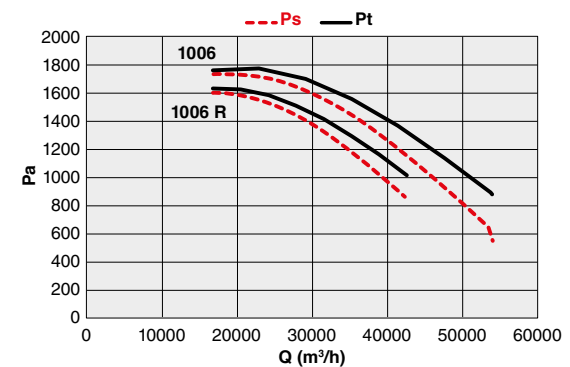
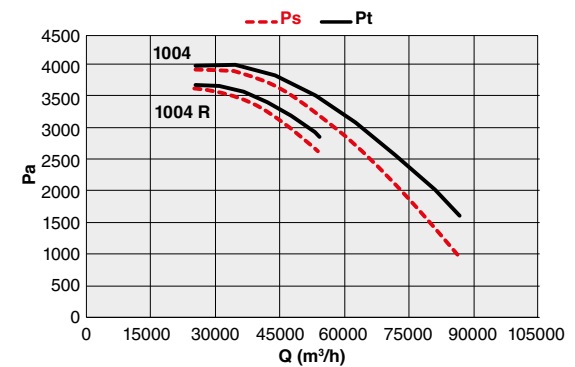

PR-L 1120

Code	Tipo Type	Modello Model	U	P	Pm (kW)	In (A)	IE3	IP/CL
7PR1151	PR-L	1126 R	T	6	30,00	55,62	✓	55/F
7PR1152		1126	T	6	37,00	68,00	✓	55/F

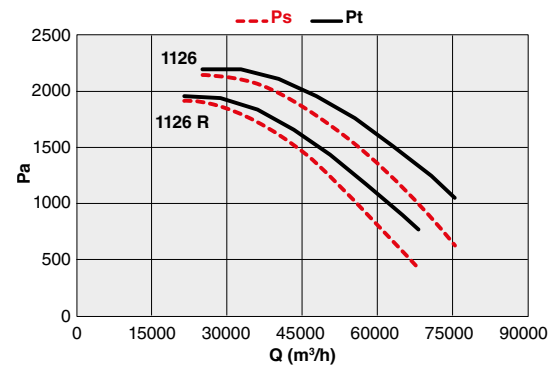

PR-L 1250

Code	Tipo Type	Modello Model	U	P	Pm (kW)	In (A)	IE3	IP/CL
7PR1153	PR-L	1256 R	T	6	55,00	96,24	✓	55/F
7PR1154		1256	T	6	75,00	159,67	✓	55/F

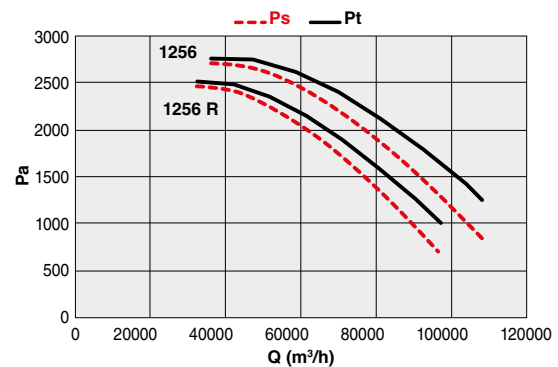

PR-L 1400

Code	Tipo Type	Modello Model	U	P	Pm (kW)	In (A)	IE3	IP/CL
7PR1406	PR-L	1406 R	T	6	90,00	159,97	✓	55/F
7PR1407		1406	T	6	110,00	195,78	✓	55/F

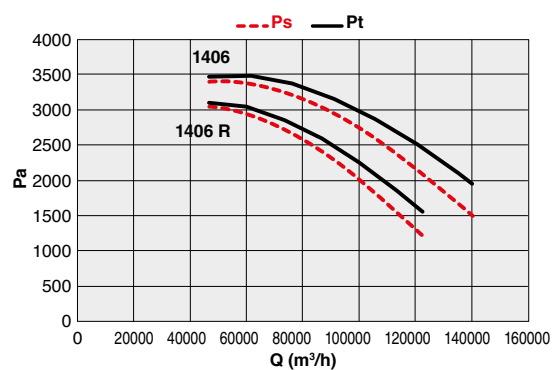

DIMENSIONI | DIMENSIONS mm

PR-L

ESECUZIONE 4 ARRANGEMENT 4

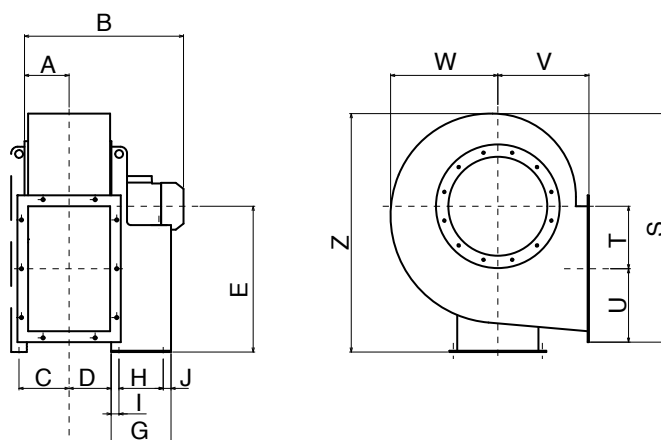

Supporto anteriore
opzionale fino al
modello 500
The front support
is optional up to
model 500

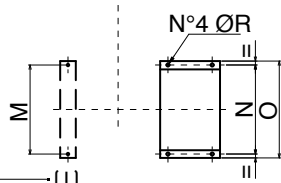

PR-L 250-500

TIPO TYPE	A	B	C	D	E	G	H	I	J	M	N	O	ØR	Z	S	T	U	V	W
PR-L 252	94	464	110	96	315	196	315	49	26	280	203	225	10	527	525	149	164	195	276
PR-L 282	105	482	123	105	375	217	121	48	48	315	203	225	10	605	586	172	184	200	305
PR-L 312	117	553	135	117	400	251	133	58	60	350	234	260	10	656	653	196	201	225	332
PR-L 314	117	452	135	117	400	151	86	45	20	350	184	206	10	656	653	196	201	225	332
PR-L 352	130	611	153	131	450	285	197	34	54	395	289	324	12	738	725	216	221	255	375
PR-L 354	130	509	153	131	450	195	121	48	26	395	203	195	10	738	725	216	221	255	375
PR-L 402 R	147	664	174	147	500	285	197	34	54	445	289	324	12	811	798	245	242	285	400
PR-L 402	147	710	174	147	500	345	237	44	64	445	337	372	12	811	798	245	242	285	400
PR-L 404 R	147	565	174	147	500	217	121	46	50	445	203	225	10	811	798	245	242	285	400
PR-L 404	147	565	174	147	500	271	121	48	48	445	203	225	10	811	798	245	242	285	400
PR-L 452 R	163	751	191	165	560	345	237	44	64	495	337	372	12	913	895	275	267	320	445
PR-L 452	163	860	191	165	560	440	337	55	54	495	395	440	14	913	895	275	267	320	445
PR-L 454 R	163	600	191	165	560	225	121	46	50	495	203	225	10	913	895	275	267	320	445
PR-L 454	163	647	191	165	560	260	133	58	60	495	234	260	10	913	895	275	267	320	445
PR-L 502 R	183	913	211	185	600	446	337	55	54	545	395	440	14	1000	997	303	294	360	502
PR-L 502	183	913	211	185	600	446	337	55	54	545	395	440	14	1000	997	303	294	360	502
PR-L 504 R	183	687	211	185	600	251	133	58	60	545	234	260	10	1000	997	303	294	360	502
PR-L 504	183	718	211	185	600	285	197	34	54	545	289	324	12	1000	997	303	294	360	502
PR-L 506 R	183	640	211	185	600	217	121	48	48	545	203	225	10	1000	997	303	294	360	502
PR-L 506	183	640	211	185	600	217	121	48	48	545	203	225	10	1000	997	303	294	360	502

.SEZ
1.5

PR-L aspiratori | centrifugal fans

ESECUZIONE 4 ARRANGEMENT 4

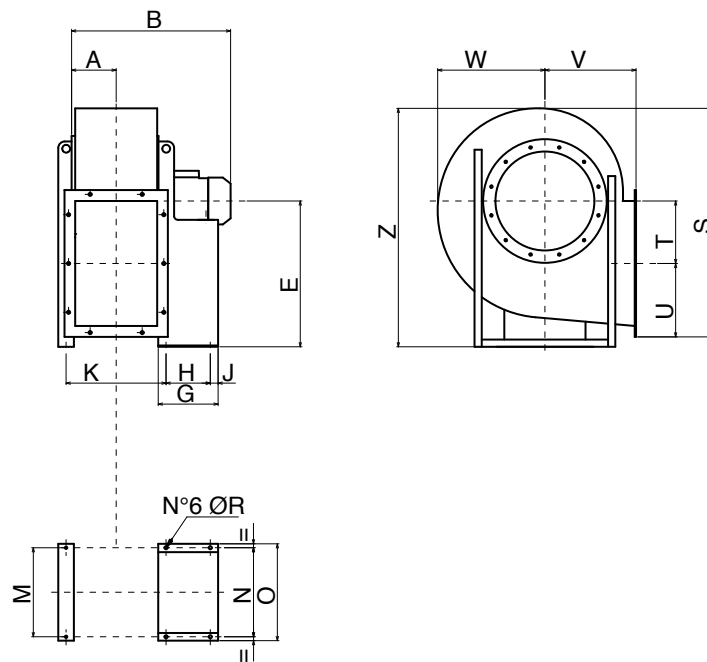

PR-L 560-1400

TIPO TYPE	A	B	E	G	H	J	K	N	O	ØR	M	Z	S	T	U	V	W
PR-L 564 R	205	774	670	280	197	54	468	289	324	12	632	1154	1151	332	335	400	570
PR-L 564	205	795	670	280	197	54	468	289	324	12	632	1154	1151	332	335	400	570
PR-L 566 R	205	743	670	247	133	60	493	234	260	10	632	1154	1151	332	335	400	570
PR-L 566	205	743	670	247	133	60	493	234	260	10	632	1154	1151	332	335	400	570
PR-L 634 R	230	885	750	340	237	64	527	337	372	12	702	1290	1282	373	369	450	630
PR-L 634	230	885	750	340	237	64	527	337	372	12	702	1290	1282	373	369	450	630
PR-L 636 R	230	824	750	280	197	54	517	289	324	12	702	1290	1282	373	369	450	630
PR-L 636	230	845	750	280	197	54	517	289	324	12	702	1290	1282	373	369	450	630
PR-L 714 R	257	1045	850	439	316	60	606	772	826	20	772	1417	1402	427	408	500	690
PR-L 714	257	1045	850	439	316	60	606	772	826	20	772	1417	1402	427	408	500	690
PR-L 716 R	257	940	850	336	201	75	606	772	826	20	772	1417	1402	427	408	500	690
PR-L 716	257	940	850	336	201	75	606	772	826	20	772	1417	1402	427	408	500	690
PR-L 804 R	287	1188	950	463	361	39	668	862	926	20	862	1601	1590	478	461	560	782
PR-L 804	287	1188	950	463	361	39	668	862	926	20	862	1601	1590	478	461	560	782
PR-L 806 R	287	1002	950	336	201	75	668	862	926	20	862	1601	1590	478	461	560	782
PR-L 806	287	1002	950	336	201	60	668	862	926	20	862	1601	1590	478	461	560	782
PR-L 904 R	322	1367	1060	540	441	39	731	962	1026	20	962	1783	1770	538	509	630	870
PR-L 904	322	1427	1060	540	441	39	731	962	1026	20	962	1783	1770	538	509	630	870
PR-L 906 R	322	1196	1060	436	316	60	731	962	1026	20	962	1783	1770	538	509	630	870
PR-L 906	322	1328	1060	460	361	39	731	962	1026	20	962	1783	1770	538	509	630	870
PR-L 1004 R	360	1632	1180	600	500	45	803	1056	1128	20	1056	1994	1985	607	564	710	976
PR-L 1004	360	1635	1180	690	590	45	803	1056	1128	20	1056	1994	1985	607	564	710	976
PR-L 1006 R	360	1482	1180	500	400	45	803	1056	1128	20	1056	1994	1985	607	564	710	976
PR-L 1006	360	1482	1180	500	400	45	803	1056	1128	20	1056	1994	1985	607	564	710	976
PR-L 1126 R	404	1611	1320	540	415	45	926	1178	1268	24	1178	2252	2251	684	635	800	1084
PR-L 1126	404	1719	1320	600	415	45	926	1178	1268	24	1178	2252	2251	684	635	800	1084
PR-L 1256 R	452	1818	1500	690	565	45	1023	1310	1400	24	1310	2547	2521	770	704	900	1214
PR-L 1256	452	2030	1500	800	675	45	1023	1310	1400	24	1310	2547	2521	770	704	900	1214
PR-L 1406 R	507	2330	1700	800	645	55	1152	1450	1560	24	1450	2835	2770	854	781	1000	1325
PR-L 1406	507	2330	1700	800	645	55	1152	1450	1560	24	1450	2835	2770	854	781	1000	1325

ESECUZIONE 1 ARRANGEMENT 1

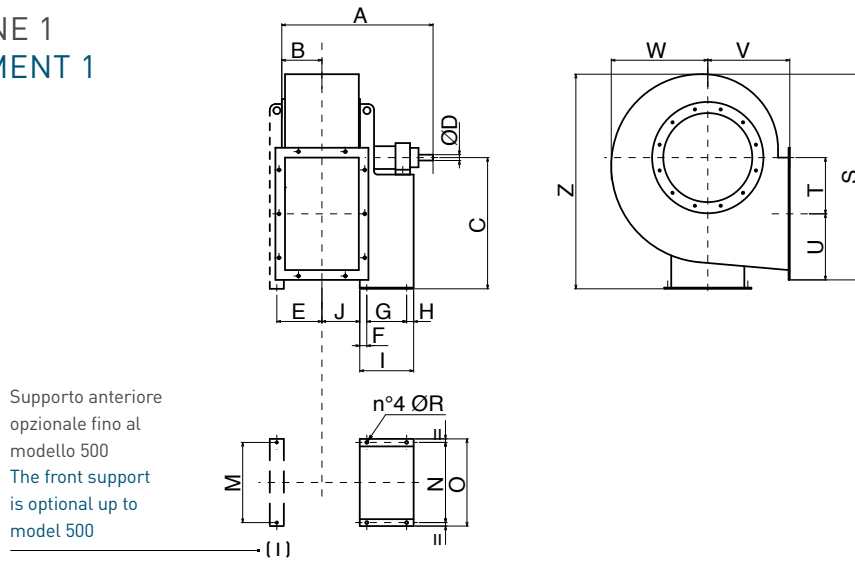

PR-L 310-500

TIPO TYPE	A	B	C	ØD	E	F	G	H	I	J	M	N	O	ØR	S	T	U	V	W	Z
PR-L 250	550	94	315	19	110	55	210	17	282	96	280	228	255	10	525	149	164	195	276	527
PR-L 280	655	105	375	24	123	40	284	23	347	105	315	288	324	12	586	172	184	200	305	605
PR-L 310	680	117	400	24	135	40	284	23	347	117	350	288	324	12	653	196	201	225	332	656
PR-L 350	860	130	450	28	153	50	407	28	485	131	395	355	400	14	725	216	221	255	375	738
PR-L 400	910	147	500	38	174	50	407	28	485	147	445	355	400	14	798	245	242	285	400	811
PR-L 450	930	163	560	38	191	50	407	28	485	165	495	355	400	14	895	275	267	320	445	913
PR-L 500	1084	183	600	42	211	50	477	33	560	185	545	364	418	17	997	303	294	360	502	1000

ESECUZIONE 1 ARRANGEMENT 1

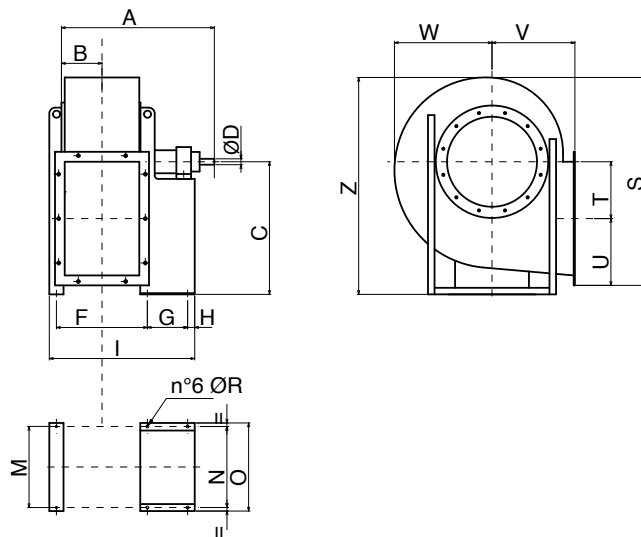

PR-L 560-1400

TIPO TYPE	A	B	C	ØD	F	G	H	I	M	N	O	ØR	S	T	U	V	W	Z
PR-L 560	1177	205	670	48	468	477	33	1021	632	632	692	17	1151	332	335	400	570	1154
PR-L 630	1233	230	750	48	527	477	33	1070	702	702	762	17	1282	373	369	450	630	1290
PR-L 710	1340	257	850	48	600	551	39	1217	772	772	826	19	1402	427	408	500	690	1417
PR-L 800	1422	287	950	55	662	551	39	1299	862	862	926	19	1590	478	461	560	782	1601
PR-L 900	1491	322	1060	55	731	551	39	1368	962	962	1026	19	1770	538	509	630	870	1783
PR-L 1000	1710	360	1180	65	803	607	45	1522	1056	1056	1128	19	1985	607	564	710	976	1994
PR-L 1120	1941	404	1320	75	926	760	45	1786	1178	1178	1268	24	2251	684	635	800	1084	2252
PR-L 1250	2038	452	1500	75	1023	760	45	1883	1310	1310	1400	24	2521	770	704	900	1214	2547
PR-L 1400	2252	507	1700	80	1152	780	55	2072	1450	1450	1560	24	2770	854	781	1000	1325	2835

BOCCA ASPIRANTE | INTEL CONE

TIPO TYPE	ØR	ØS	ØT	n° F	Ø G
PR-L 250	255	292	325	8	10
PR-L 280	285	332	365	8	12
PR-L 310	320	366	400	8	12
PR-L 350	360	405	440	8	12
PR-L 400	405	448	485	12	12
PR-L 450	455	497	535	12	12
PR-L 500	505	551	585	12	14
PR-L 560	565	629	665	12	14
PR-L 630	635	698	735	12	14
PR-L 710	715	775	815	16	14
PR-L 800	805	861	905	16	14
PR-L 900	905	958	1005	16	14
PR-L 1000	1007	1067	1107	24	14
PR-L 1120	1130	1200	1250	24	14
PR-L 1250	1260	1337	1380	24	17
PR-L 1400	1420	1491	1540	32	17

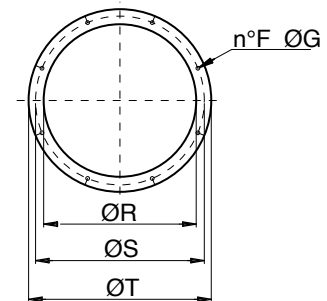

BOCCA PREMENTE | OUTLET CONE

TIPO TYPE	A	B	a1	b1	a2	b2	N1 x p	N2 x p	n° D	Ø E
PR-L 250	258	185	292	219	328	255	1x112	2x112	10	12
PR-L 280	288	205	332	249	368	285	1x125	2x125	10	12
PR-L 310	322	229	366	273	402	309	1x125	2x125	10	12
PR-L 350	361	256	405	300	441	336	1x125	2x125	10	12
PR-L 400	404	288	448	332	484	368	2x125	3x125	14	12
PR-L 450	453	322	497	366	533	402	2x125	3x125	14	12
PR-L 500	507	361	551	405	587	441	2x125	3x125	14	12
PR-L 560	569	404	629	464	669	504	2x160	3x160	14	14
PR-L 630	638	453	698	513	738	553	2x160	3x160	14	14
PR-L 710	715	507	775	567	815	607	2x160	4x160	16	14
PR-L 800	801	569	871	639	921	689	2x200	3x200	14	14
PR-L 900	898	638	968	708	1018	758	3x200	4x200	18	14
PR-L 1000	1007	715	1077	785	1127	835	3x200	4x200	18	14
PR-L 1120	1130	801	1210	881	1270	941	3x200	5x200	20	18
PR-L 1250	1267	898	1347	978	1407	1038	4x200	6x200	24	18
PR-L 1400	1421	1007	1501	1087	1561	1147	4x200	6x200	24	18

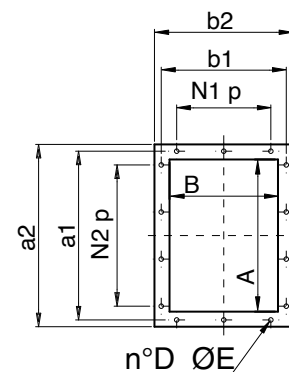

DIMENSIONI E ORIENTAMENTI mm

PR-L

DIMENSIONS AND DISCHARGE ANGLES

Dimensioni dei modelli secondo l'orientamento.

Dimensions of models according to the discharge angle.

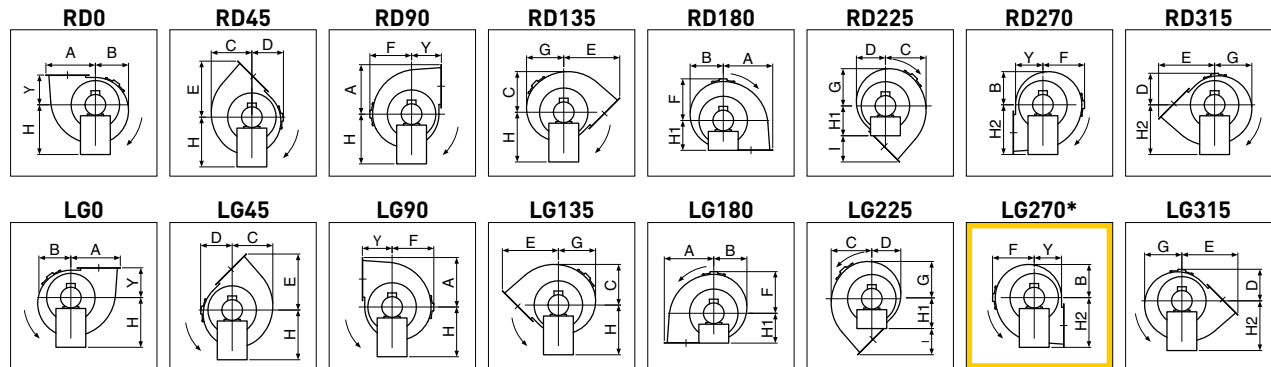

* Versione standard | Standard version.

TIPO TYPE	A	B	C	D	E	F	G	I	Y	H	H1	H2
PR-L 250	313	212	255	215	359	276	235	164	195	315	195	315
PR-L 280	356	230	287	226	393	305	262	193	200	375	200	375
PR-L 310	397	256	316	253	440	332	288	215	225	400	225	400
PR-L 350	437	289	359	278	492	375	325	237	255	450	255	450
PR-L 400	487	311	387	306	543	400	353	258	285	500	285	500
PR-L 450	542	354	435	342	609	445	398	289	320	560	320	560
PR-L 500	597	401	490	380	676	502	450	316	360	600	360	600
PR-L 560	667	485	555	425	754	570	542	354	400	670	400	670
PR-L 630	742	540	619	476	843	630	603	393	450	750	450	750
PR-L 710	835	568	719	497	944	690	662	444	500	850	500	850
PR-L 800	939	652	811	562	1061	782	749	501	560	950	560	950
PR-L 900	1047	723	905	633	1186	870	835	556	630	850	630	1060
PR-L 1000	1171	815	1015	718	1330	976	936	620	710	950	710	1180
PR-L 1120	1319	932	1132	793	1498	1084	1037	698	800	1060	800	1320
PR-L 1250	1474	1048	1270	898	1679	1214	1163	779	900	1190	900	1500
PR-L 1400	1635	1136	1395	990	1863	1325	1272	863	1000	1320	1000	1700

PESI | WEIGHTS

Modello Model	Kg*
PR-L 252	37
PR-L 282	45
PR-L 312	57
PR-L 314	43
PR-L 352	80
PR-L 354	65
PR-L 402 R	95
PR-L 402	116
PR-L 404 R	75
PR-L 404	75
PR-L 452 R	124
PR-L 452	161
PR-L 454 R	89
PR-L 454	94
PR-L 502 R	187
PR-L 502	196
PR-L 504 R	123

Modello Model	Kg*
PR-L 504	130
PR-L 506 R	115
PR-L 506	117
PR-L 564 R	153
PR-L 564	158
PR-L 566 R	141
PR-L 566	145
PR-L 634 R	202
PR-L 634	214
PR-L 636 R	173
PR-L 636	180
PR-L 714 R	315
PR-L 714	315
PR-L 716 R	276
PR-L 716	276
PR-L 804 R	465
PR-L 804	465

Modello Model	Kg*
PR-L 806 R	367
PR-L 806	367
PR-L 904 R	840
PR-L 904	847
PR-L 906 R	556
PR-L 906	658
PR-L 1004 R	1105
PR-L 1004	1278
PR-L 1006 R	879
PR-L 1006	885
PR-L 1126 R	1153
PR-L 1126	1242
PR-L 1256 R	1739
PR-L 1256	1980
PR-L 1406 R	2630
PR-L 1406	2651

* Pesi indicativi | Indicative weights



LATO ASPIRANTE | INLET SIDE

Flangia - Rete - Giunto | Flange - Guard - Flexible connector

Flangia Flange	Rete Guard	Giunto Connector	Tipo Type	ØR	ØS	ØT	F	ØG	L
5B01323	5RE4050	5SU1096	250	255	292	325	8	10	145
5B01364	5RE1027	5SU3147	250	285	332	365	8	12	145
5B01334	5RE1002	5SU3101	310	320	366	400	8	12	145
5B01330	5RE1022	5SU3500	350	360	405	440	8	12	145
5B01347	5RE5606	5SU1102	400	405	448	485	12	12	145
5B08105	5RE1046	5SU1406	450	455	497	535	12	12	145
5B01380	5RE1180	5SU1180	500	505	551	585	12	14	180
5B08087	5RE1016	5SU8004	560	565	629	665	12	14	180
5B01391	5RE1013	5SU9000	630	635	698	735	12	14	180
5B08101	5RE1015	5SU1100	710	715	775	815	16	14	180
5B01357	5RE0815	5SU8000	800	805	861	905	16	14	180
5B01359	5RE0090	5SU9002	900	905	958	1005	16	14	230
5B01408	5RE1010	5SU1144	1000	1007	1067	1107	24	14	230
5B01398	5RE1011	5SU1145	1120	1130	1200	1250	24	14	230
5B01409	5RE1014	5SU1146	1250	1260	1337	1380	24	17	230
5B01404	5RE1012	5SU3077	1400	1420	1491	1540	32	17	230

Dimensioni in mm | Dimensions in mm

FLANGIA | FLANGE

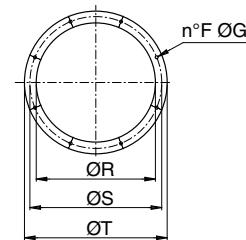

RETE | GUARD

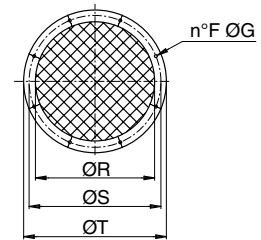

GIUNTO | FLEXIBLE CONNECTOR

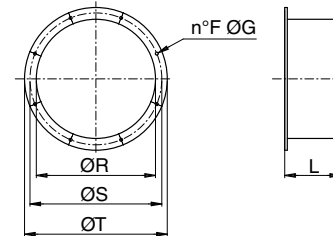

LATO PREMENTE | OUTLET SIDE

Flangia - Rete - Giunto | Flange - Guard - Flexible connector

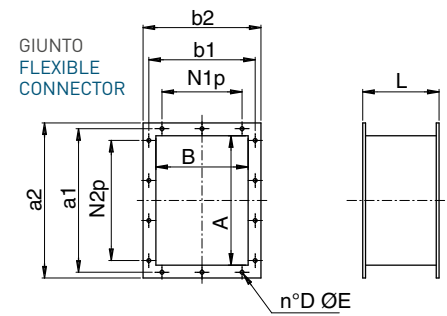
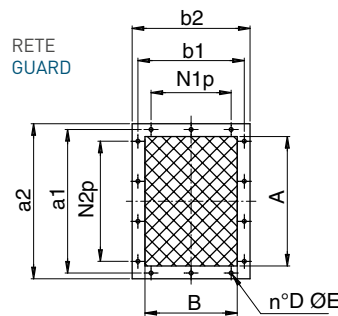
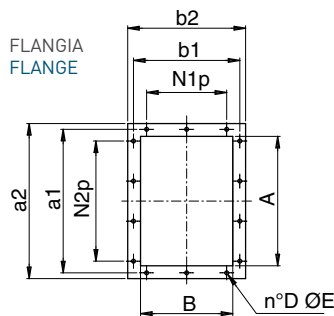

Flangia Flange	Rete Guard	Giunto Connector	Tipo Type	A	B	a1	b1	a2	b2	N1 x p	N2 x p	n° D	Ø E	L
5B01324	5RE3138	5SU3138	250	258	185	292	219	328	255	1 x 112	2 x 112	10	12	145
5B01365	5RE1130	5SU1130	250	288	205	332	249	368	285	1 x 125	2 x 125	10	12	145
5B01362	5RE1348	5SU3148	310	322	229	366	273	402	309	1 x 125	2 x 125	10	12	145
5B01340	5RE1023	5SU3501	350	361	256	405	300	441	336	1 x 125	2 x 125	10	12	145
5B01344	5RE1020	5SU4023	400	404	288	448	332	484	368	2 x 125	3 x 125	14	12	145
5B01348	5RE1006	5SU5601	450	453	322	497	366	533	402	2 x 125	3 x 125	14	12	145
5B01381	5RE1024	5SU1181	500	507	361	551	405	587	441	2 x 125	3 x 125	14	12	145
5B08104	5RE1004	5SU4021	560	569	404	629	464	669	504	2 x 160	3 x 160	14	14	180
5B01310	5RE1035	5SU1402	630	638	453	698	513	738	553	2 x 160	3 x 160	14	14	180
5B01390	5RE1009	5SU1101	710	715	507	775	567	815	607	2 x 160	4 x 160	16	14	180
5B01392	5RE3079	5SU3079	800	801	569	871	639	921	689	2 x 200	3 x 200	14	14	180
5B01360	5RE9003	5SU9003	900	898	638	968	708	1018	758	3 x 200	4 x 200	18	14	180
5B08100	5RE1128	5SU1128	1000	1007	715	1077	785	1127	835	3 x 200	4 x 200	18	14	180
5B01399	5RE1399	5SU1399	1120	1130	801	1210	881	1270	941	3 x 200	5 x 200	20	18	180
5B01413	5RE1413	5SU1413	1250	1267	898	1347	978	1407	1038	4 x 200	6 x 200	24	18	180
5B01405	5RE3078	5SU3078	1400	1421	1007	1501	1087	1561	1147	4 x 200	6 x 200	24	18	180

Dimensioni in mm | Dimensions in mm